

CHOP-CHECK STYLE LOWER PUMP ENDS

Also covers 637290-X4X and 637291-X4X service kits



**READ THIS MANUAL CAREFULLY BEFORE INSTALLING,
OPERATING OR SERVICING THIS EQUIPMENT.**

It is the responsibility of the employer to place this information in the hands of the operator. Keep for future reference.

SERVICE KITS

- Use only genuine ARO® replacement parts to assure compatible pressure rating and longest service life.
- **637290-X4X** for general repair of **67100-X4X** lower pump ends.
- **637291-X4X** for general repair of **67101-X4X** lower pump ends.

GENERAL DESCRIPTION

⚠ WARNING DO NOT EXCEED MAXIMUM OPERATING PRESSURE AS INDICATED ON PUMP MODEL PLATE.

⚠ WARNING REFER TO GENERAL INFORMATION SHEET FOR ADDITIONAL SAFETY PRECAUTIONS AND IMPORTANT INFORMATION.

- This manual covers the lower pump section. It is one of four documents which support an ARO pump. Replacement copies of these forms are available upon request.
 - 650XXX-X Pump Model Operator's Manual.
 - General Information for Air Operated or Hydraulically Operated Pumps.
 - Lower Pump End Operator's Manual.
 - Air or Hydraulic Motor Operator's Manual.
- The chop-check design provides for easy priming of the lower foot valve. The double acting feature is standard in all ARO industrial pumps. Material is delivered to the pump discharge outlet on both the up and down stroke.

MAINTENANCE

The air / hydraulic motor is completely separate from the lower pump end. This helps to keep the motor from being contaminated by the material being pumped. Periodically, flush entire pump system with a solvent that is compatible with the material being pumped.

Keep solvent cup filled with this compatible solvent. This will keep material from drying on the piston rod, which would drag thru the packings, ruin them and eventually scour the piston rod.

Provide a clean work surface to protect sensitive internal moving parts from contamination from dirt and foreign matter during disassembly and reassembly.

Before reassembling, lubricate parts as required. When assembling "O" rings, or parts adjacent to "O" rings, exercise care to prevent damage to "O" rings and "O" ring groove surface.

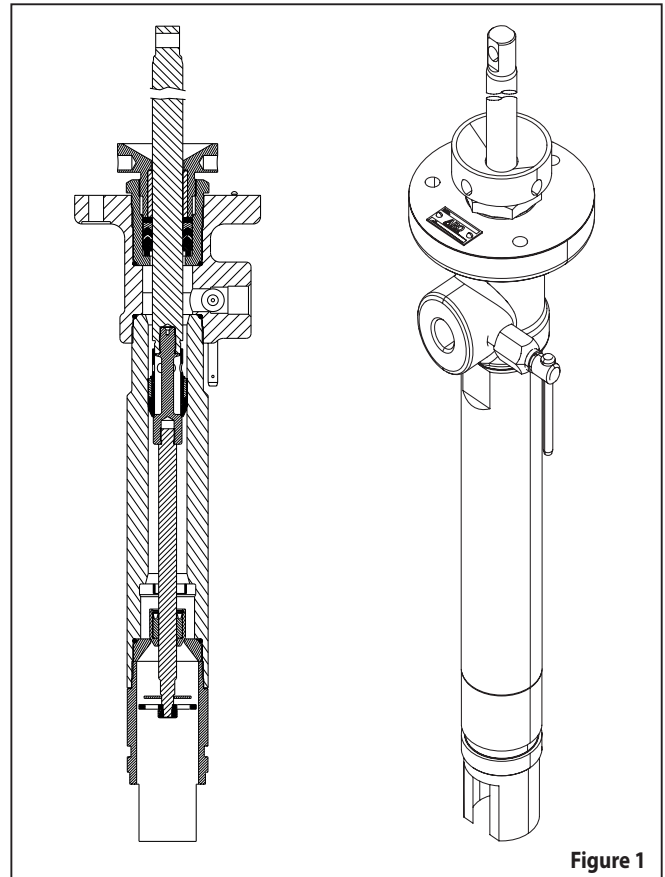

Figure 1

LOWER PUMP END DESCRIPTION CHART

6710 X - X 4 X	
Pump Material 0 - Carbon steel 1 - Stainless steel	
Packing Material F - UHMW-PE / Leather staggered (upper) - UHMW-PE (lower) P - UHMW-PE / Glass filled PTFE staggered (upper) - UHMW-PE (lower)	
Spring Arrangement 4 - Multiple wave spring	
Plunger Type 3 - Hardened stainless steel with hard chrome plating 8 - Hardened stainless steel with alternate piston	
Service Kit Selection	6710X - X 4 X 63729X - X 4 X
Example: Lower Pump End # 67100-P43 Service Kit # 637290-P43	Packing — Plunger

PART LIST / 6710X-XXX

Item	Description (size)	(Qty)	Part No.	Mtl
1	Nut (models 67100-X4X)	(1)	93980-1	[C]
	(models 67101-X4X)	(1)	93980-2	[SS]
2	Washer	(1)	93981	[SH]
✓ 3	Washer	(1)	93983-1	[UH]
✓ 4	"V" Packing (models 6710X-P4X)	(2)	93714-2	[GFT]
	(models 6710X-F4X)	(2)	93714-1	[L]
✓ 5	"V" Packing	(3)	93714-4	[UH]
6	Washer	(1)	93984	[SS]
7	Wave Spring	(1)	93955	[SH]
8	Tube (models 67100-X4X)	(1)	93977-1	[C]
	(models 67101-X4X)	(1)	93977-2	[SH]
✓ 9	Ring	(1)	93969-1	[SS]
✓ 10	Seal (models 6710X-X43)	(1)	93971-1	[UH]
	(models 6710X-X48)	(1)	94498-1	[UH]
✓ 11	Seal (models 67100-X4X)	(1)	93972-1	[D]
	(models 67101-X4X)	(1)	93972-2	[PPS]
12	Piston (models 67100-X4X)	(1)	93974-1	[C]
	(models 67101-X4X)	(1)	93974-2	[SH]
13	Stop	(1)	93954	[SH]
✓ 14	Retaining Ring (0.042" thick x 0.859" OD)	(1)	Y147-77-5	[SS]
✓ 15	"U" Cup	(1)	90757	[GFT]
16	Valve (models 67100-X4X)	(1)	93957-1	[C]
	(models 67101-X4X)	(1)	93957-2	[SH]
✓ 17	"O" Ring (3/32" x 1-13/16" OD)	(1)	Y328-130	[T]

MATERIAL CODE

[Br] = Brass	[L] = Leather
[Bz] = Bronze	[PPS] = Polyphenylene Sulfide
[C] = Carbon Steel	[SH] = Hard Stainless Steel
[D] = Acetal	[SS] = Stainless Steel
[DI] = Ductile Iron	[T] = PTFE
[GFT] = Glass filled PTFE	[UH] = UHMW-PE

LOWER PUMP DISASSEMBLY

NOTE: All threads are right hand.

1. Secure the lower pump assembly in a vise, clamping on (29) body.
2. Unscrew (27) gland and remove assembly from lower end. Set this assembly aside.
3. Unscrew (22) nut and remove (21) washer (20) plate.
4. Unscrew (30) primer tube and remove from (8) tube. Remove (18) seat and (17) "O" ring from (8) tube.
5. Unscrew (8) tube from (29) body. (14) retaining ring, (15) "U" cup and (16) valve will slide off (19) primer rod. Remove (13) stop from (8) tube using a pair of long nose pliers and squeezing on (13) stop (see figure 3).
6. Remove (25) plunger, (23) valve rod and (19) primer rod from (8) tube.
7. Unscrew and remove (19) primer rod from (23) valve rod. Remove (12) piston, (11) seal, (10) seal and (9) ring from (25) plunger.
8. Unscrew (1) nut and remove (28) bushing, (2) washer, (3) female washer, (4 and 5) "V" packings, (6) male washer and (7) wave spring from (27) gland.

Item	Description (size)	(Qty)	Part No.	Mtl
18	Seat (models 67100-X4X)	(1)	93978-1	[C]
	(models 67101-X4X)	(1)	93978-2	[SH]
19	Primer Rod (models 67100-X4X)	(1)	93959-1	[C]
	(models 67101-X4X)	(1)	93959-2	[SH]
20	Plate	(1)	93966	[SS]
21	Washer	(1)	93965	[SS]
22	Lock Nut (1/4" - 28)	(1)	95977302	[SS]
23	Valve Rod (models 67100-X4X)	(1)	93956-1	[C]
	(models 67101-X4X)	(1)	93956-2	[SH]
✓ 24	"O" Ring (3/32" x 1-13/16" OD)	(1)	Y328-130	[T]
25	Plunger	(1)	94047-2	[SH]
✓ 26	"O" Ring (3/32" x 1-13/16" OD)	(1)	Y328-130	[T]
27	Gland (models 67100-X4X)	(1)	93953-1	[C]
	(models 67101-X4X)	(1)	93953-2	[SS]
✓ 28	Bushing	(1)	93976-2	[PPS]
29	Body (models 67100-X4X)	(1)	93952-1	[DI]
	(models 67101-X4X)	(1)	93952-2	[SS]
30	Primer Tube (models 67100-X4X)	(1)	93979-1	[C]
	(models 67101-X4X)	(1)	93979-2	[SS]
31	Valve	(1)	62113	[SS]
✓	Parts in Repair Kit (models 67100-X4X)		637290-X4X	
✓	Parts in Repair Kit (models 67101-X4X)		637291-X4X	

LOWER PUMP REASSEMBLY

NOTE: Inspect and replace old parts with new parts as necessary. Look for deep scratches on metallic surfaces and nicks or cuts in "O" rings. Refer to sealant and torque notes on page 3.

1. Assemble (11) seal and (10) seal to (12) piston, securing with (9) ring. **NOTE:** Refer to figure 2 for direction of lips on (10) seal. Apply Loctite® 242® to threads of (23) valve rod and assemble (12) piston and (23) valve rod to (25) plunger.
2. Apply Loctite 242 to threads of (19) primer rod and assemble to (23) valve rod.
3. Apply Loctite nickel anti-seize to threads of (1) nut and assemble (7) wave spring, (6) male washer, (5 and 4) "V" packings, (3) female washer, (2) washer, (28) bushing and (1) nut to (27) gland. **NOTE:** Do not tighten.
4. Place plunger assembly (see step 1) thru top end of (29) body.
5. Install (13) stop into (8) tube (see figure 3).
6. Apply Loctite nickel anti-seize to threads of (8) tube and assemble (24) "O" ring and (8) tube over piston assembly and into (29) body. **NOTE:** Tighten to 240 ft lbs. (325.4 Nm).
7. Assemble (15) "U" cup into (16) valve, securing with (14) retaining ring. Assemble (16) valve and components to (19) primer rod.
8. Assemble (17) "O" ring and (18) seat into (8) tube. Apply Loctite nickel anti-seize to threads of (30) primer tube and assemble to (8) tube. **NOTE:** Tighten to 240 ft lbs. (325.4 Nm).
9. Assemble (20) plate and (21) washer to (19) primer rod, securing with (22) nut.
10. Slide (25) plunger into (27) gland and screw assembly into (29) body and tighten. **NOTE:** Tighten (27) gland to 240 ft lbs. (325.4 Nm).

PART LIST / 6710X-XXX

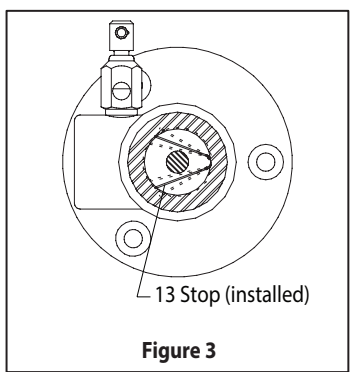
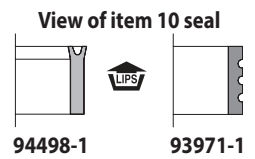
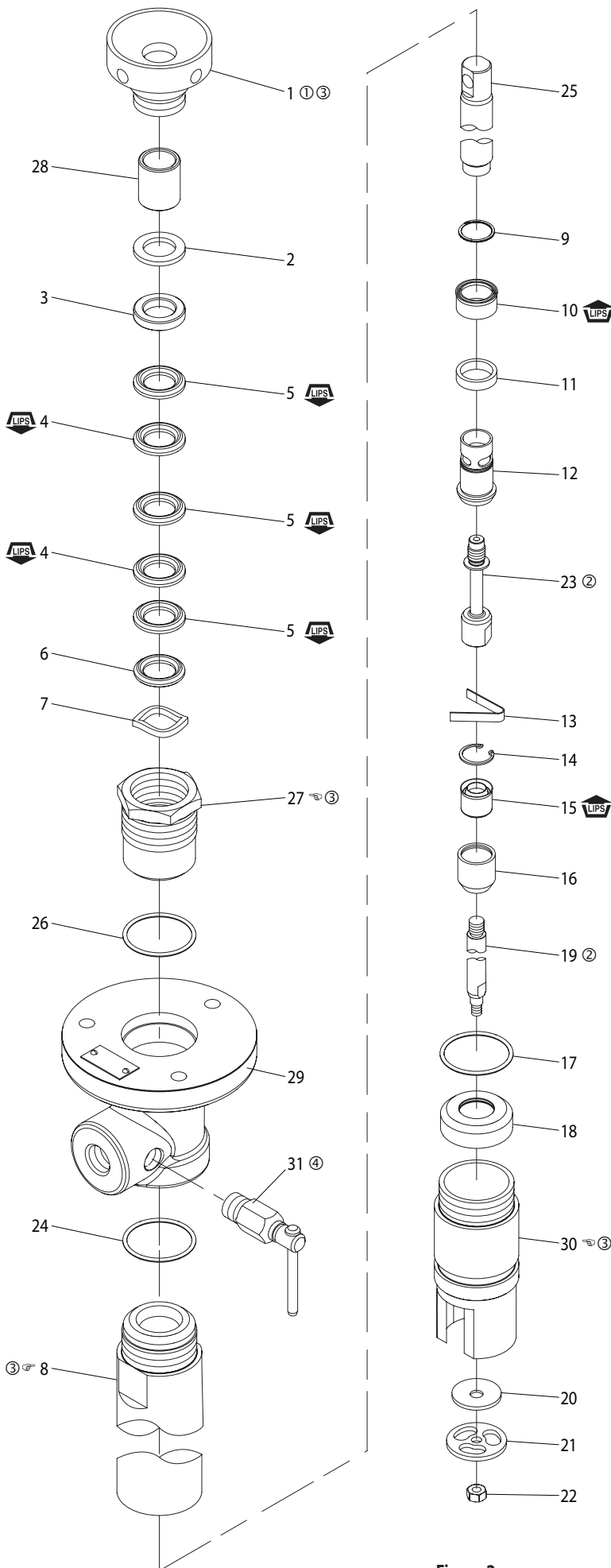

TORQUE REQUIREMENTS

NOTE: DO NOT OVERTIGHTEN COMPONENTS.

(8) tube, 240 ft lbs. (325.4 Nm).
 (27) gland, 240 ft lbs. (325.4 Nm).
 (30) primer tube, 240 ft lbs. (325.4 Nm).

LUBRICATION AND SEALANTS

① Keep solvent cup filled with a lubricant such as Wet Sol "Plus" or equivalent.
 ② Clean threads and apply Loctite 242.
 ③ Apply Loctite nickle anti-seize.
 ④ Apply anaerobic pipe sealant with PTFE.

Figure 2

• ARO® is a registered trademark of Ingersoll Rand Company •
 • Loctite® and 242® are registered trademarks of Henkel Loctite Corporation •

TROUBLESHOOTING

No material at outlet (pump continually cycles).

- Check material supply. Disconnect or shut off the air supply and replenish the material, reconnect.

Material on one stroke only (fast downstroke).

- The lower check may not be seating in the foot valve (see lower pump disassembly). Remove the check from the foot valve, clean and inspect the valve seat area. If check or foot valve are damaged, replace.

Material on one stroke only (fast upstroke).

- The middle packings may be worn (see lower pump disassembly). Replace the seals as necessary.

Material leakage out of the solvent cup or material appears on the pump plunger rod.

- Tighten the solvent cup until leakage discontinues . If this procedure does not aid in stopping the leakage problem, the upper packings may be worn (see lower pump disassembly). Replace the seals as necessary.